

L. E. WHITON.
LATHE CHUCK.

No. 551,425.

Patented Dec. 17, 1895.

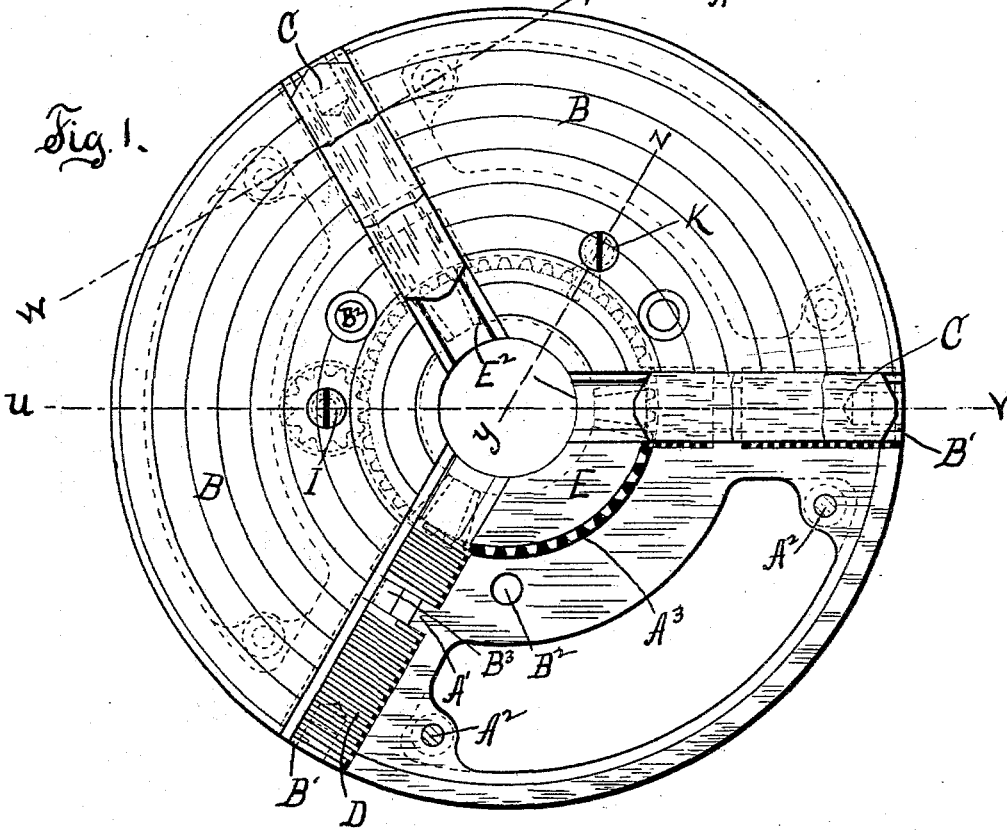
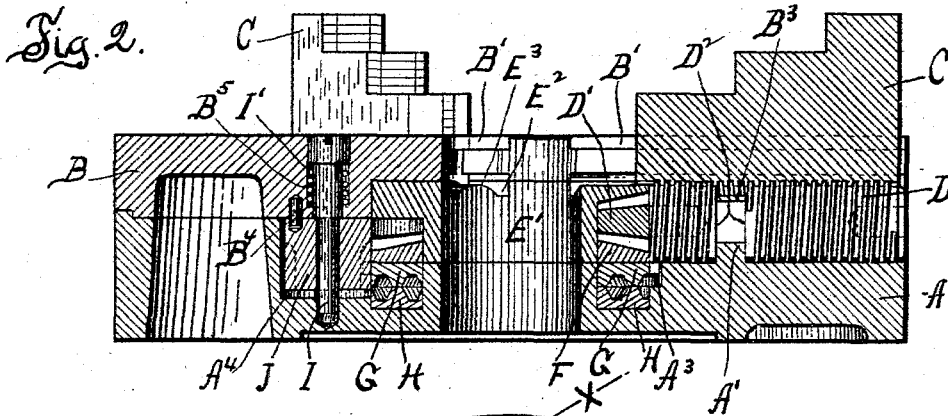

WITNESSES:

Abraham Luther.
Lila D. Peale.

INVENTOR

Lucius E. Whiton

BY

Frank H. Allen,

ATTORNEY

L. E. WHITON.
LATHE CHUCK.

No. 551,425.

Patented Dec. 17, 1895.

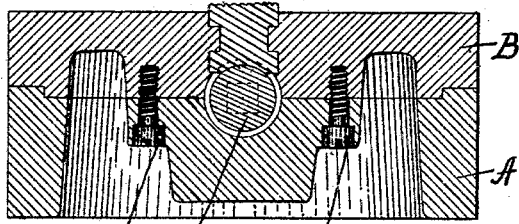

Fig. 3.

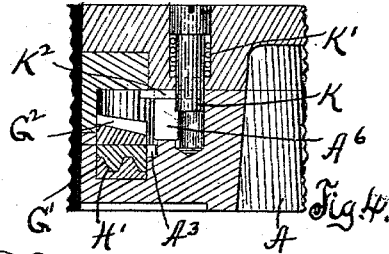

Fig. 4.

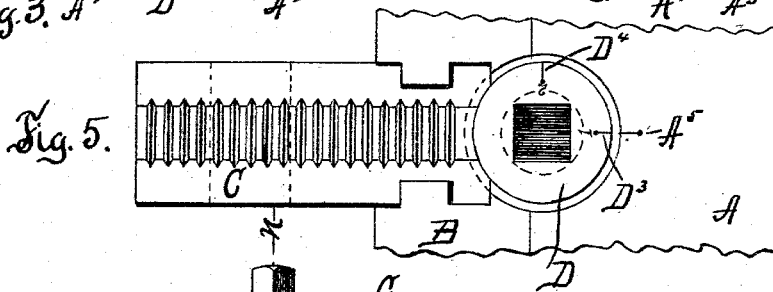

Fig. 5.

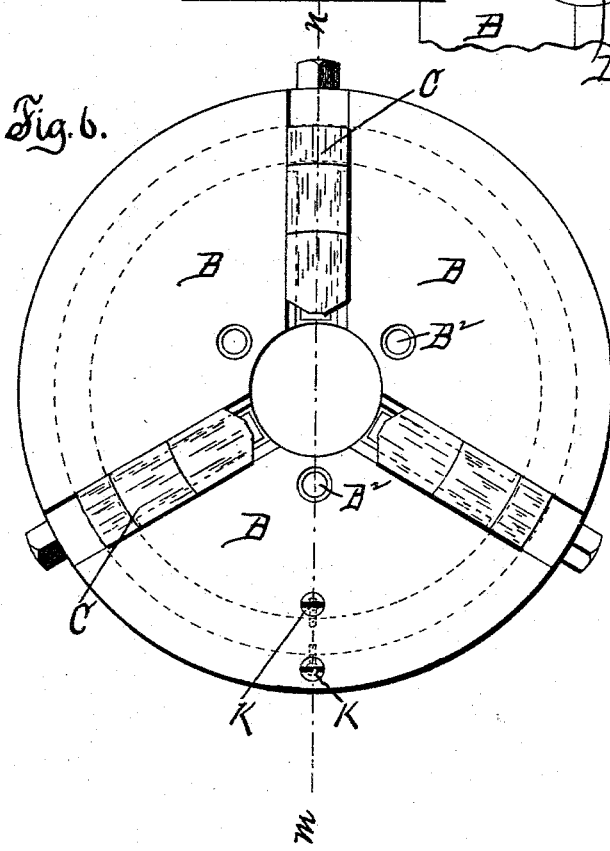

Fig. 6.

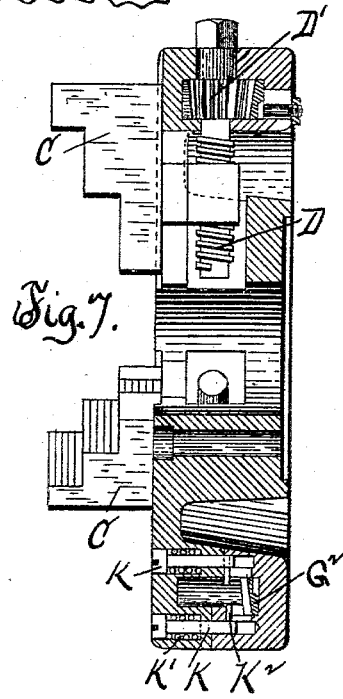

Fig. 7.

WITNESSES:

Alvord Luther.
Lila D. Peale.

INVENTOR
Lucius E. Whiton,
BY
Frank H. Allen,
ATTORNEY

UNITED STATES PATENT OFFICE.

LUCIUS E. WHITON, OF NEW LONDON, CONNECTICUT.

LATHE-CHUCK.

SPECIFICATION forming part of Letters Patent No. 551,425, dated December 17, 1895.

Application filed September 28, 1894. Serial No. 524,416. (No model.)

To all whom it may concern:

Be it known that I, LUCIUS E. WHITON, a citizen of the United States, residing in the city and county of New London and State of Connecticut, have invented a new and useful Improvement in Lathe-Chucks, of which

the following is a specification.

My invention relates to what are known as "combination-chucks," wherein the jaws are moved by screws which may be revolved independently or together at will, and is a further improvement upon the chuck for which I have been granted Letters Patent No. 369,758, dated September 13, 1887.

The objects of my invention are, first, to so design the frame as to provide largely-increased strength to withstand the strains exerted by the jaws when gripping the work, and to simplify the construction of the various parts; second, to provide an improved form of cam-ring for raising the rack into engagement with the several pinions, and more convenient means for operating and locking the same, and, third, to provide convenient means for adjusting the rack which connects the several screws, so that it may be readily thrown into engagement whenever desired. These objects are attained by the mechanism and arrangement of parts illustrated in the accompanying drawings and hereinafter described.

In the drawings, Figure 1 is a face view of a chuck embodying these improvements, with one jaw and one section of the front plate of the chuck removed to better display the construction of the parts. Fig. 2 is a central cross-section on line *uv* of Fig. 1. Fig. 3 is a section taken on line *wx* of Fig. 1. Fig. 4 is a partial section taken on the line *yz* of Fig. 1. Fig. 5 is an end elevation of one of the jaws and the screw which operates it, with a portion of the frame within which they are mounted. Fig. 6 is a plan view of a combination-chuck of ordinary construction, showing the application of my improved rack-adjusting device, and Fig. 7 is a central cross-section taken on line *mn* of Fig. 5.

Referring to the drawings, A is the back plate forming one of the main castings of the improved chuck, and B represents the several front sections of the said frame.

C represents the series of radially-moving

jaws operated within suitable slots B' by means of screws D. These screws are of the same form as shown in Letters Patent above referred to, are located in radial cylindrical recesses similar to those described therein, and are provided at their inner ends with pinions D', as before, but are held in place against radial displacement by annular ribs A' projecting into the said recesses and formed as integral portions of the castings A and B. One or more such annular ribs A' for each recess may be provided, as desired, within the scope of my invention; but the chuck herein shown has only one such rib within each recess, fitting the central abutting shoulders D² of the screws D.

The two frame castings A and B are joined together at the plane of the axes of the several screws D and are fastened by a series of screws A², as shown most clearly in Fig. 3. These castings are also fastened by a series of bolts (not shown) through the chuck, located in holes B², Fig. 1, by which the chuck is secured to the flange of the lathe-spindle. Before any of the operations of manufacture have been performed the portions A and B of the frame are each suitably-shaped castings of one piece only and are conveniently subjected to the processes of fitting and finishing to the required sizes, but after having been joined together the process of finishing the several radial slots and cylindrical recesses within which the jaws and screws operate cuts the casting B into a series of segments joined only by slender portions B³ of the annular ribs A' above referred to. The segments are usually broken apart at these points to avoid the necessity for undue care in handling.

The form of the castings A and B is such as to provide a central annular chamber A³ prolonged within the casting B. To inclose this annular chamber A³ so as to exclude all chips and dirt which would otherwise prevent the proper operation of the mechanism of the chuck, a third central frame-casting E having the annular hub E' is fitted within the casting B in the prolongation of the chamber A³, as shown. The upper face of the casting E is provided with radial slots E², which coincide with and form a portion of the radial slots B', within which the jaws C slide.

These radial slots E² have raised cylindrical bottoms E³ corresponding in diameter with the screws D at the bottom of their threads, as shown and described in the former patent.

5 Beneath the cylindrical bottoms of slots E² are conical recesses within which the pinions D' revolve. The projecting annular hub E' of this central casting is made of proper length to abut against the casting A, as shown, while its upper face abuts against the casting B. It will thus be seen that this central casting E effectually incloses the annular chamber A³, and protects the mechanism mounted therein without projecting to either exterior face of the completed chuck, and that it is not liable to any displacement. On account of forming the annular ribs A', which hold the screws D in place against radial displacement, as integral portions of the castings A and B, I avoid cutting the recesses for the several thrust-plugs formerly required to hold the screws in place and afford a very much larger section of metal to withstand the strains of the chuck when in use. I also save the entire cost of making and fitting these several thrust-plugs. By this improved method of forming the frame in two sections, which are joined at the plane of the axes of the several screws, I am also enabled to greatly simplify the construction of the central annular chamber within which the mechanism of the chuck is mounted and to render the said chamber and its contained parts less liable to accidental injury or displacement.

35 Beneath the rack F within the annular chamber A³ are cam-rings G and H, of which G is loosely mounted so as to revolve upon the fixed ring H. When so revolved, G causes rack F to rise into engagement with pinions D', as shown in Fig. 2, or permits it to fall out of such engagement, as shown in Fig. 4. The faces of these cam-rings are formed with oppositely-disposed beveled scroll-threads G' and H' operating as described in the former patent; but the threads of the improved cam-rings herein shown are of increased pitch and of the variety known as "double," formed in the same manner as the well-known double screw-thread, and have both their outer and inner faces beveled. The movable cam-ring G is also provided with a complete series of gear-teeth G² instead of a segment of such teeth, as formerly constructed.

55 I is a suitable shaft journaled in the frame sections B and A parallel with the axis of the chuck, and has fixed upon its lower end within recess A⁴ a pinion J, whose teeth are in mesh with those of the cam-ring G and sufficiently long to accommodate its rise and fall. The upper surface of pinion J is provided with a hole fitted by the projecting end of a pin B⁴ fixed in B near the shaft I. A spring I' within the recess B³ tends to keep the pinion J in engagement with said pin; but the recess A⁴ is sufficiently deep to permit disengagement by pressure. When so disengaged, the pin-

ion J may be revolved, and will move the ring G also. The spring will tend to lock the pinion J upon the completion of a revolution, and will afford a self-acting indication of such revolution to the operator. In the former construction of the cam-rings G and H, the loose ring was incapable of continuous revolution, but had only a forward and backward movement on account of the use of a gear-segment instead of a complete series of gear-teeth. It was also necessary to give the operating-pinion more than one revolution in a certain direction when connecting or disconnecting the several chuck-screws, and there was no means of automatically indicating the locking-point to the operator. The improved form of the cam-rings herein described enables the loose ring to revolve continuously and smoothly in either direction, and a single revolution of the pinion J in either direction is sufficient to accomplish the necessary movement of the cam-ring G and consequent rise or fall of the rack F. Upon the completion of this revolution the cam-ring is locked against further movement by the engagement of pinion J with pin B⁴, as above described. It is thus only necessary to depress the shaft I and give it a single revolution in either direction to change the arrangement of the chuck so that the jaws will operate independently or together, as desired. This greatly increases the convenience of operation and is an important advantage afforded by the improved form of cam-rings and locking devices herein described. Obviously the fixed cam-surfaces H' may be formed integral with the frame A, if desired, within the scope of my invention; but I have deemed it preferable to insert a separate ring H on account of greater facility in construction.

In the use of combination-chucks it is often desirable to set the jaws independently to a true circle having the axis of the chuck for its center, so that circular work may be held exactly true, after which the several jaws are connected and operated together in chucking and releasing such work; but hitherto it has been found that after setting the jaws to such a position (indicated usually by concentric circles upon the face of the chuck) and upon attempting to connect the several chuck-screws by lifting the rack into engagement therewith, that frequently the rack-and-pinion teeth would not be properly located to permit such engagement, and that the connection could not readily be made. In such cases it has been necessary to disturb the concentric adjustment of the jaws by turning the pinions slightly until the rack would engage, as a result of which the chuck-jaws when connected would not chuck circular work exactly true.

To provide convenient means for setting the jaws accurately true, and for adjusting the rack so that it may be readily engaged without disturbing the position of the jaws, I furnish the frame A of the chuck with a mark,

as A⁵, near each screw, (see Fig. 5,) and when the jaws are known to be set accurately, as in the process of finishing their gripping-faces, I mark the end of each screw with separate marks D³ D⁴, which are made opposite the mark A⁵. The mark D³ is made when the jaws are inserted with their lower ends toward the center, and the mark D⁴ when inserted in the reversed position. In connection with concentric circles made on the face of the chuck, these marks enable the operator to conveniently set the jaws independently and accurately whenever desired. A suitable shaft K (see Fig. 4) is journaled in a frame-section B parallel to the axis of the chuck, with its lower end projecting into the recess A⁶, which communicates with the central annular chamber A³. This shaft is normally held in the position shown in Fig. 4 by the spring K'. The lower end of this shaft K has a projection K² extending into the annular chamber A³ above the rack F, and adapted to engage with its gear-teeth when depressed. Whenever it is found that rack F does not readily rise into mesh with the several pinions D' it is only necessary to depress K until its projection K² engages with the rack, when a slight rotary movement of K will move the rack sufficiently to permit it to engage with the pinions without difficulty. Thus the several screws and jaws may be connected without disturbing their concentric adjustment, leaving the chuck set perfectly true.

These several features are matters of very great convenience in the use of the chuck, and afford important advantages over previous constructions.

This frequent difficulty in engaging the rack with the several screw-pinions without disturbing their adjustment is common to all chucks operated by screws which may be connected or disconnected by a circular rack, and it is obvious that the above-described improved device for adjusting the rack into the proper position to engage the several screw-pinions may be readily applied to such chucks of whatever construction, without regard to the means used for raising the rack. In Figs. 6 and 7, I have shown the application of this device in two positions to one variety of such chucks. In either position the operation of the device is essentially the same as before described, and a further detailed description will therefore be unnecessary.

I am aware that chucks have heretofore been constructed with a hole drilled through the frame exactly above the rack, through which a separate tool can be inserted to set its teeth in a certain position, so that if the screw-pinions are also properly located the rack will readily rise into engagement; but this is a device which makes it necessary to

locate the screw-pinions with regard to the rack rather than for adjusting the rack to the pinions. It also makes an opening which will admit dirt to the mechanism and requires the use of a separate tool, which is easily lost or misplaced. In the improved construction herein described no opening is left which will admit chips or dirt to the gearing. In chucks embodying my improved means of operating the connecting-rack, the same tool serves also to adjust either device, as required.

I am also aware that it is not new to provide index-marks upon chuck-screws, and therefore disclaim these as forming no part of my present invention.

I claim—

1. In a lathe chuck, the combination, with two sections A and B, provided with radial recesses, one of the sections, A, being provided with a central annular chamber which is prolonged into the other section, a central frame having an annular hub fitting within the prolongation of the chamber, a toothed rack around the central frame, a screw within each radial recess, the inner end of which is provided with a gear pinion, a jaw for each screw, and means for moving the rack into and out of engagement with the pinions, substantially as set forth.

2. In a lathe chuck consisting of a suitable frame, a series of sliding jaws, and operating mechanism therefor, the combination of the cam rings (G and H) having opposite beveled double scroll threads upon their surfaces, substantially as and for the purpose described.

3. In a lathe chuck consisting of a suitable frame, a series of sliding jaws, and operating mechanism therefor, the combination of a revoluble cam ring having a complete series of gear teeth (G²); a depressible and revoluble shaft (I) provided with pinion (J) in mesh therewith, and having a stop pin recess (J'); a fixed stop pin (B⁴) adapted to enter said recess; and a spring tending normally to hold said pinion in engagement with said stop pin for the purpose of locking said revoluble cam ring, substantially as described.

4. The combination in a lathe chuck, with a suitable frame or chuck body, of a series of sliding jaws, a series of actuating screws engaging therewith and provided with gear pinions; a connecting revoluble gear rack (F), means for raising said rack into engagement with said screw pinions; and a depressible and revoluble shaft (K) having projection (K²) adapted to engage with the gear teeth of said rack when depressed; substantially as and for the purpose described.

LUCIUS E. WHITON.

Witnesses:

D. E. WHITON,
FRANK H. ALLEN.